

# MasterCue V6

## User Manual



Cueing and Presentation Control Specialists

## **Contents:**

<b>Introduction</b>	<b>3</b>
<b>MasterCue Range Features</b>	<b>3</b>
<b>Safety Instructions</b>	<b>4</b>
<b>Conformity</b>	<b>6</b>
<b>Operating Instructions</b>	<b>10</b>
<b>Programming Handsets to Receiver</b>	<b>12</b>
<b>Programming the 'Click' Relay</b>	<b>12</b>
<b>Programming Special Cues</b>	<b>12</b>
<b>Special Requirements</b>	<b>13</b>
<b>RF System</b>	<b>14</b>
<b>Troubleshooting</b>	<b>14</b>
<b>System Protection Features</b>	<b>15</b>
<b>Equipment Supplied</b>	<b>15</b>
<b>Technical Support Contact</b>	<b>15</b>

## Introduction

**MasterCue V6** is the latest in over 12 years of Cueing systems from Interspace Industries. Building on its breeding from the previous systems and listening to you, the users, of these systems.

Reliability is still at the forefront of our systems. Our remote RF receiver still ensures reliable positioning away from the Technician and the amassed electronics ( laptops, Screens Video etc..) that may cause interference. We have kept the wired button as standard for guaranteed cueing, but it is now possible to “Y” split the handsets with a Splexler (1xWired handset supplied as standard).

Confidence Lamp as standard, this is now included to run out in front of the Presenter for enhanced confidence that the system is working (Using Splexler more can be used—see later).

3xUSB ports with independent enable/disable control for up to 3 computers as well as a Cue4 Output for addition drive if required. For PowerPoint™ Keynote™ or Impress™ presentation software packages.

The visual and audible cues are easy to understand and designed to clearly indicate which button has been pushed and what cue action is required.

If a production intercom system is being used, the audible cues can be injected into the operators headset using the Comms Loop-through feature on either 4-pin or 5-pin Headsets (mono or Stereo).

Rack Ears can be purchased to make the MasterCue V6 rack mount

***MasterCue - when a missed cue is  
simply NOT an option!***

We hope **MasterCue V6** exceeds your expectations and welcome any feedback that you have about this or any of our products.

Thank you.

The Interspace Industries Team  
[www.interspaceind.com](http://www.interspaceind.com)

## Safety Instructions

All safety and operating instructions should be read before this product is operated and should be retained for further reference. Please adhere to all the warnings on this product and in these operating instructions. Please follow these instructions carefully.

**Power.** Only use the power source indicated on the device. Devices equipped with a grounded plug should only be used with a grounded type outlet. In no way should this grounding be disconnected, modified or suppressed.

**Power Supply Lead.** To unplug the device always pull by the plug itself, not the power supply lead. The power source outlet should always be near the MasterCue main unit and easily accessible. Ensure the power supply lead cannot be walked on or damaged by items placed on or against it. **Do not use if the power supply lead is damaged.** Using the device with a damaged power supply lead may expose you to electric shock or other hazards. Check the condition of the power supply lead regularly. Contact your dealer or service centre immediately for a replacement if damaged.

### Keep Away From Harmful Substances

To prevent the risk of electric shock and fire, do not expose this device to rain, humidity or intense heat sources (such as radiators or direct sunlight). Avoid using this equipment in environments where there is excessive heat, dust, moisture, chemicals, vibration or mechanical shocks.

**Slots and Openings.** These are designed into the device for ventilation and to avoid overheating. Always ensure these openings remain clear. **Do not attempt to insert anything into these openings under any circumstances.** If liquids have been spilled on, or objects have fallen into the product it must be checked by a qualified technician before re-using.

**Connections.** All inputs and outputs (except for power input) are TBTS defined under EN60950.

- **DO NOT OPEN SYSTEM DUE TO HIGH VOLTAGE.**
- **DO NOT IMMERSE IN WATER.**

If you have any queries regarding these safety instructions or how to maintain the unit please do not hesitate to contact us on:

**+44 (0) 1462 600101**

**Servicing.** Do not attempt to service this product yourself. Should an unauthorised person attempt to either open the covers or service our products, it may invalidate your Limited Factory Warranty. In addition, opening or removing covers and screws may expose you to electric shocks or other hazards. Refer all servicing to qualified service personnel.

# Diagrams

Figure 1: MasterCue V<sup>6</sup> Connections Diagram

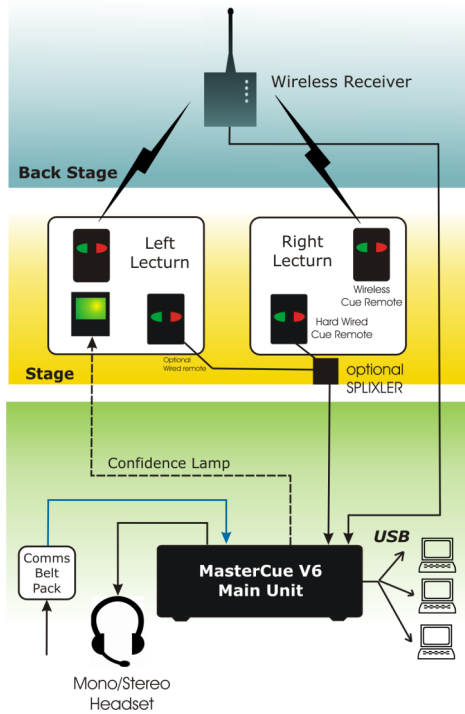
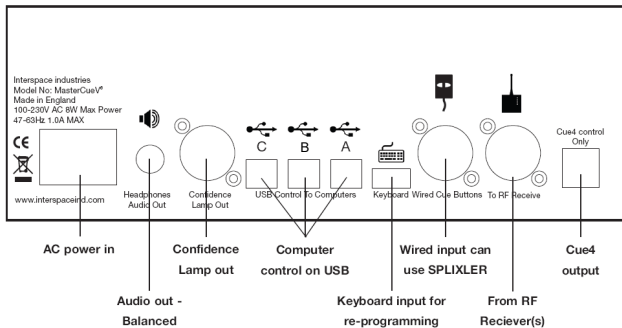

Figure 2: MasterCue V<sup>6</sup> Rear Panel



## FCC STATEMENTS

**Interspace Industries**  
*MasterCue* Range of Products  
Made In UK.

This device complies with Part 15 of the FCC Rules. Operation is subject to the following two conditions:

(1) This device may not cause harmful interference, and (2) this device must accept any interference received, including interference that may cause undesired operation.

Interspace Industries  
Unit 1A, 126 Great North Road  
Hatfield, Hertfordshire  
AL9 5JN  
United Kingdom  
+44 (0) 1462 600101 : Out of hours +44 (0) 7976 385 046

**Warning !** Any modification or changes made to this device, unless explicitly approved by Company name, will invalidate the authorisation of this device. Operation of an unauthorised device is prohibited under Section 302 of the Communications Act of 1934, as amended, and Subpart I of Part 2 of Chapter 47 of the Code of Federal Regulations.

NOTE: This equipment has been tested and found to comply with the limits for a Class B digital device, pursuant to Part 15 of the FCC Rules. These limits are designed to provide reasonable protection against harmful interference in a residential installation. This equipment generates, uses and can radiate radio frequency energy and, if not installed and used in accordance with the instructions, may cause harmful interference to radio communications. However, there is no guarantee that interference will not occur in a particular installation. If this equipment does cause harmful interference to radio or television reception, which can be determined by turning the equipment off and on, the user is encouraged to try to correct the interference by one or more of the following measures:

- Reorient or relocate the receiving antenna.
- Increase the separation between the equipment and receiver.
- Connect the equipment into an outlet on a circuit different from that to which the receiver is connected.
- Consult the dealer or an experienced radio/TV technician for help.

## FCC COMPLIANCE INFORMATION STATEMENT DECLARATION OF CONFORMITY

Manufacturer:	Interspace Industries
Responsible Party in the USA:	Interspace Industries 4650 South Butterfield Drive Tucson AZ, 85714 Tel Office: 520 689 4237
Product:	MasterCue Range of Products
Authorisation Procedure:	Declaration of Conformity

This device complies with Part 15 of the FCC Rules. Operation is subject to the following two conditions: (1) this device may not cause harmful interference, and (2) this device must accept any interference received, including interference that may cause undesired operation.

We, Interspace Industries, have determined that the above named equipment has been shown to comply with the applicable technical standards. Furthermore, we warrant that each unit of equipment marketed is identical to the unit tested and found acceptable with the standards. The records maintained continue to reflect the equipment being produced within the variation that can be expected due to quantity production and testing on a statistical basis.

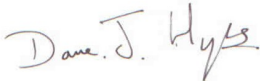

David J Humphrys, Managing Director  
Interspace Industries  
Unit 1A, 126 Great North Road  
Hatfield, Hertfordshire  
AL9 5JN  
United Kingdom

May 2011

## EC DECLARATION OF CONFORMITY TO R&TTE DIRECTIVE 1995/5/EC

Manufacturer:	Interspace Industries
Product:	MasterCue Range of Products
Conformity Assessment:	Annex III; Internal production control plus specific apparatus tests

Reference standards used for presumption of conformity:

Article 3.1a EN 60950-1:2006/A1:2010

Article 3.1b EN 301 489-3 v1.4.1.

Article 3.2 EN 300 220-3 v1.1.1.

### Declaration

We, Interspace Industries, declare under our sole responsibility that the essential radio test suites have been carried out and that the above product to which this declaration relates is in conformity with all the applicable essential requirements of EU Directive 1995/5/EC

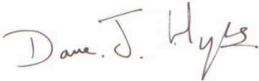

David J Humphrys, Managing Director  
Interspace Industries  
Unit 1A, 126 Great North Road  
Hatfield, Hertfordshire  
AL9 5JN  
United Kingdom

May 2011

---

## EC DECLARATION OF CONFORMITY TO R&TTE DIRECTIVE 1995/5/EC

English	Hereby, Interspace Industries, declares that this "MasterCue" is in compliance with the essential requirements and other relevant provisions of Directive 1999/5/EC.
Finnish	Interspace Industries vakuuttaa täten että "MasterCue" tyypin laite on direktiivin 1999/5/EY oleellisten vaatimusten ja sitä koskevien direktiivin muiden ehtojen mukainen.
Swedish	Härmed intygar Interspace Industries att denna "MasterCue" står i överensstämmelse med de väsentliga egenskapskrav och övriga relevanta bestämmelser som framgår av direktiv 1999/5/EG.



Danish	Undertegnede Interspace industries erklærer herved, at følgende udstyr "MasterCue" overholder de væsentlige krav og øvrige relevante krav i direktiv 1999/5/EF
Dutch	Hierbij verklaart Interspace industries dat het toestel "MasterCue" in overeenstemming is met de essentiële eisen en de andere relevante bepalingen van richtlijn 1999/5/EG
	Bij deze verklaart Interspace industries dat deze "MasterCue" voldoet aan de essentiële eisen en aan de overige relevante bepalingen van Richtlijn 1999/5/EC.
French	Par la présente Interspace Industries déclare que l'appareil "MasterCue" est conforme aux exigences essentielles et aux autres dispositions pertinentes de la directive 1999/5/CE
	Par la présente, Interspace Industries déclare que ce "MasterCue" est conforme aux exigences essentielles et aux autres dispositions de la directive 1999/5/CE qui lui sont applicables
German	Hiermit erklärt Interspace Industries, dass sich dieser/diese/dieses "MasterCue" in Übereinstimmung mit den grundlegenden Anforderungen und den anderen relevanten Vorschriften der Richtlinie 1999/5/EG befindet". (BMW)
	Hiermit erklärt Interspace Industries die Übereinstimmung des Gerätes "MasterCue" mit den grundlegenden Anforderungen und den anderen relevanten Festlegungen der Richtlinie 1999/5/EG. (Wien)
Greek	ΜΕ ΤΗΝ ΠΑΡΟΥΣΑ Interspace Industries ΔΗΛΩΝΕΙ ΟΤΙ "MasterCue" ΣΥΜΜΟΡΦΩΝΕΤΑΙ ΠΡΟΣ ΤΙΣ ΟΥΣΙΩΔΕΙΣ ΑΠΑΙΤΗΣΕΙΣ ΚΑΙ ΤΙΣ ΛΟΙΠΕΣ ΣΧΕΤΙΚΕΣ ΔΙΑΤΑΞΕΙΣ ΤΗΣ ΟΔΗΓΙΑΣ 1999/5/ΕΚ
Italian	Con la presente Interspace Industries dichiara che questo "MasterCue" è conforme ai requisiti essenziali ed alle altre disposizioni pertinenti stabilite dalla direttiva 1999/5/CE.
Spanish	Por medio de la presente Interspace Industries declara que el "MasterCue" cumple con los requisitos esenciales y cualesquiera otras disposiciones aplicables o exigibles de la Directiva 1999/5/CE
Portuguese	Interspace Industries declara que este "MasterCue" está conforme com os requisitos essenciais e outras disposições da Directiva 1999/5/CE.

## Environmental

**WEEE and RoHS Compliance.** The MasterCue range and all associated accessories have been manufactured and sold in accordance with the requirements of the EC WEEE and RoHS directives. Please return all end-of-life items to your supplier, or Interspace Industries directly, for appropriate disposal.

### Packaging Materials:

Cardboard box: Grade 150 K/T 'B' (Single Walled Corrugated - Brown Kraft)  
Protective Foam: Grade HLB 22 Grey Foam (High Load Bearing)

## Electrical

**CE Mark.** The MasterCue range and all associated accessories have been designed, manufactured and certified to comply with all requirements of the European CE standard.

---

## Operating Instructions

**Unpacking and Connections.** Unpack the main unit and place on a flat surface within easy access for the operator. Refer to fig 2 for connector locations. If using the keyboard for special cue programming, please see this separate section also.

**Main Unit, Receiver Unit and Handsets. (Refer Fig 1)** Place the RF receiver unit behind the stage in close proximity to the wireless handsets being used (not closer than 2 metres as signal overloading may occur). **Ensure the antenna is vertical.** Connect this to the 'RF Receiver' input on the MasterCue V6 main unit using a standard 3-pin XLR cable. Connect the wired handset to the 'Wired Cue Button' input on the MasterCue V6 main unit also using standard 3-pin XLR cables.

It is important to ensure the 3-pin XLR cables do not have phase reverse. The cables must be wired pin to pin. Standard connections are:

1. Common ground and power return
2. Signal and DC Power
3. Signal and DC Power.

### Comms Loop-through. 4-Pin and 5-Pin—Use only one type.

If the operator wants to hear the audible cue tones through their intercom headset, the operator's intercom system belt pack should be positioned near the MasterCue V6 main unit. The two Comms Loop-through connectors on the main unit are bi-directional, so simply unplug the headset from the belt pack and then plug it into the matching 'Comms Loop-through' connection on the main unit. Connect one end of the blue Comms adaptor lead (supplied with MasterCue V6) into the now vacant 4 or 5 pin connector on the belt pack. Insert the other end into the remaining 4 or 5 pin 'Comms Loop-through' connector on the MasterCue V6 main unit. This system is designed to work with most available intercom systems that have 4 and 5 pin XLR connectors on the headset. Use the Left /Right switch on stereo headsets to select which ear to hear the tones in.

**Power.** Insert the power IEC socket into the rear of the main unit and the power plug into a suitable power outlet. Turn on the power source.

**Start-up.** The system will do a short test, during which the display on the main unit will show that it is working correctly. Check the system by pressing any of the handset buttons to give a cue. The display on the main unit will show that a cue has been received.

**Resetting the Main Unit.** To reset the main unit to all the factory default settings, disconnect the power from the main unit, wait 20 seconds and then press and hold the down arrow button beside the main display on the main unit while reconnecting the power. The unit will attempt to start and pause when the main display shows the volume level at maximum. Release the down arrow button and the system will then re-start and restore all factory defaults.

**Internal Speaker.** Normal reset setting of the internal speaker function is off. The speaker can be turned on and off using the button on the front panel of the main unit. This does not affect the audio output via the 1/4 inch jack or the Comms Loop-through system

**Tone & Volume.** Normal reset mode for this is volume mode (on). When the Tone and Volume button is on, the arrow buttons beside the main display will control the level of the audible cue tones. A relative level will be shown on the display. When the Tone and Volume button is off, the arrow buttons will now control the tone selection and the display changes with each tone option.

**USB Devices.** Before using the computer for a presentation the USB device must be communicating with the computer. Check for this by listening for the familiar 'ding dong' tone emitting from the computer speakers when the USB is connected. Alternatively check device manager. **Failure to do so will render the MasterCue V6 unusable.**

**USB Ports Enable. (A, B, C)** Normal reset mode for this is Operator Control mode (on). This function switches between direct control of the computer running the presentation (Presenter Control), and indirect control where the operator has to control the presentation upon receiving the visual and audio cues from the presenter (Operator Control). This is connected to the computer USB port via a USB series A-B lead (provided). Once this has been selected for Presenter Control mode the unit will communicate directly with the PC and control the PowerPoint presentation.

**USB Ports Enhanced mode.** *At power-up the USB enable buttons will flash once for normal use or twice for enhanced mode. If a computer has been connected before in normal mode it will not work in enhanced mode, until it has been deleted from the device manager and then re-discovered. Or reset the port to normal mode by holding in the Port button at power-up so it only flashes once.*

**NOTE: It is recommended that you always fully test Presenter Control mode with the computer thoroughly during rehearsals!**

## Programming Handset Transmitters to Receiver

1. To program a transmitter (wireless handheld) to the receiver, using a suitable sized tool, insert into the 'Learn' aperture on the receiver module and press the internal button once so the LED glows red
2. While the 'Learn' LED is illuminated on the receiver, press any button on the transmitter (wireless handheld) and the LED will go out. The transmitter code is now programmed into the receiver
3. Repeat steps 1-2 for each additional transmitter required to work with this receiver module
4. To clear the RF system programmed memory, using a suitable sized tool, insert into the 'Learn' button aperture on the receiver module. Press and hold the internal button down for 15 seconds until the red LED goes out. All transmitter codes will then be erased.

## Diversity RF Receivers (Pseudo)

With these RF receivers it is possible to parallel 2 RF receivers via an XLR splitter (Splixler) to one MasterCue main unit. This has the possibility of a greater range over a given area or noisy environments.

## Programming the 'Click' Relay

At start-up MasterCue is programmed to use an internal relay to make an audible 'click' sound each time any cue is received. This click sound can be programmed to work for either 'NEXT' or 'BACK' cues only, or not at all if complete silence is required.

With the main unit connected to the power and turned on, press and hold the Tone/Volume button until it and the Speaker on/of flash alternately.

By momentarily pressing the ▲ button next to the visual display on the front panel of the main unit, the system will disable the click for any 'NEXT' cues only and then reset out of programming mode, ready to operate. To disable the click for 'BACK' cues also, put the system into programming mode again as above, then press the ▼ button.

Repeating either of these two procedures can re-enable the click sounds. A main unit reset (as described on p11) will also re-enable the click sounds as well as resetting all options to the factory default settings of course.

## Programming Special Cues

Presentations can be controlled in numerous ways. For example by pressing 'B' on the keyboard when in PowerPoint slide-show mode, the screen will be taken to Black, 'W' will take the screen to White, '12←' will advance to slide number 12 and '1←' will take the presentation back to the beginning of the presentation. The green 'NEXT' and red 'BACK' handset buttons can be programmed to perform special cues such as these instead of the default "NEXT" and 'BACK' commands.

With the main unit connected to the power and turned on, connect the external keyboard (USB) to the keyboard input on the rear of the MasterCue main unit. Check that the computer can be controlled from the keyboard which is now connected to the MasterCue main unit (please note that some special keys will not work; Ctrl, Fn, ALT etc ). The one keyboard will drive all three Computers—great for Editing.

Press and hold the tone/volume button MasterCue main unit until the Tone/Volume button and the Speaker on/off button flash alternately. This will put the system into programming mode. The unit can now record keystrokes made on the keyboard (up to a maximum of 4 keystrokes).

Press the keys on the keyboard which will perform the special cue you require (e.g. 'B' to go to black or '1 ←' to reset to the beginning of the slideshow), then press either the 'Next' or 'Back' buttons on any of the handsets. The MasterCue will then return to normal mode and whenever the handset button you programmed is pressed during a presentation, this key-stroke sequence will be simulated. To program the second button, MasterCue will need to be put into program mode again.

Special Cues can be erased by either re-programming the standard 'Next' and 'Back' keystrokes using the cursor right (→) and cursor left (←) keystrokes, or by resetting the system as previously described.

## Special Requirements

**Cables.** Optimum performance of the MasterCue system can be assured when using cable lengths up to 200m between the handsets and the main unit, and between the RF Receiver and the main unit. This is dependant on the quality of the cable used of course and high quality microphone cable (screened pair) is recommended for optimum performance.

**Cable DC Rating.** DC power is nominal 100mA at 12V DC. This is to provide power to the external devices and also carries the signal data between these and the main unit.

**Wireless Performance.** The wireless RF system is designed to operate reliably in an open field environment up to 75m. This can be reduced when operating in an enclosed AV venue. To ensure optimum performance, please observe the following guidelines:

- Ensure the RF receiver aerial is vertically orientated
- Position the RF receiver within line-of-sight of the handsets, without large metallic objects in between, as much as possible
- Avoid electrical/electronic interference by positioning the RF receiver away from equipment as much as possible.

**USB Interface.** Suitable only for systems running a WINDOWS XP, Vista, Windows 7, Apple and Linux or later, operating system. To ensure optimum performance, we can only recommend using the USB A-B type cable supplied.

**Comms Loop-through.** The blue cables provided have been designed to work with most common 4-pin and 5-pin XLR Intercom systems. We do not recommend extending or substituting this cable. Please let us know if you discover any systems which do not work with this configuration by visiting [www.interspaceind.com](http://www.interspaceind.com) or by calling us on +44 870 770 8088.

## Radio Frequency System

The MasterCue range uses a proven RF system for all wireless applications.

Operating frequency:	434.075MHz (UK, Europe & USA)
Transmission method:	FM (Pure FSK)
Maximum transmit power:	10mW (EU) 11mV/m @3m (USA)

This frequency is open and licence exempt for UK, Europe and USA. Other countries should consult their respective authorities.

The system used is a coded transmission whereby the receivers are programmed to the transmitters which each have individual and unique codes. Nominal range of the transmitters is typically 75M in an enclosed venue.

## Trouble Shooting

### Wireless Handhelds

After checking the correct programming of the handheld to the receiver, if the main unit does **not** signal a cue when either button on the wireless handheld is pressed, check the following:

- Does the LED on the handheld illuminate when any button is pushed?
  - If not then the handheld battery may need replacing.
- Does the green LED signal strength meter on the front of the receiver show any signal when a cue button is pressed on the handheld transmitter?
  - If no, reposition the receiver to obtain better RF reception.
  - If yes, then check the Cue LED on the front of the receiver module. This normally glows amber and turns green if the green button is pushed on the handheld transmitter and red if the red button is pushed.
- If the Cue LED is working correctly, then the receiver is communicating correctly with the transmitter and the problem is likely to be with the cable connection to the main unit.
- If it is not illuminated at all then the cable connection to the main unit may also be faulty as no power is getting to the receiver unit.

### Wired Handhelds

If no cue is signalled by the main unit when either button is pushed, check the cabling between the hard wired handheld and the main unit.

## System Protection Features

### Receiver DC Volts Protection - Beeper

In case Comms ring DC volts are accidentally connected to the receiver module (possible when using a multicore/stagebox), a **beeper** within the receiver module will sound and the **red cue light** on the receiver module will glow continuously. In this state no cues can be sent to the main unit. Reconnecting the receiver to the main unit as per the operating instructions will restore the system to working order.

### Main Unit DC Volts Protection

In case Comms ring DC volts are accidentally connected to either of the hard-wired remotes inputs or the RF Receiver input on the main unit (possible when using a multicore/stagebox), the system will not receive cues from the input/s affected until the correct connection has been made as per the operating instructions.

### Wireless Transmitter Protection

To comply with Radio Frequency regulations, the wireless transmitters are designed to stop transmitting whenever either cue button is held down for 5 seconds or more. Extended periods where the buttons remain depressed will nevertheless, severely shorten the battery life. Always ensure these are packaged so the buttons cannot be accidentally held down during transit.

## Equipment Supplied

- 1 x MasterCue Main Unit
- 1x RF Receiver Unit
- 1 x Dual button wired handset
- 2 x Dual button RF transmitters (each including a standard 9V battery)
- 1 x Confidence Lamp
- 1 x IEC Power Lead
- 3 x USB cables, A-B
- 1 each, Blue 4 & 5-pin XLR coms loop-through cables

## For Technical Support or Sales Enquiries:

Interspace Industries Head Office:

**+44 (0) 1462 600101**

Emergency Technical Support Hot Line:

**+44 (0) 7976 385 046**

Website:

**[www.interspaceind.com](http://www.interspaceind.com)**



Unit 1A  
126 Great North Road  
Hatfield, Hertfordshire  
AL9 5JN  
United Kingdom  
Tel: +44 (0) 1462 600101  
Email: [moreinfo@interspaceind.com](mailto:moreinfo@interspaceind.com)  
[www.interspaceind.com](http://www.interspaceind.com)